



## ONGC VIDESH LIMITED

6<sup>th</sup> Floor, Kailash Building,  
26 K.G.Marg, New Delhi

No. OVL/7/IV/BS/DG Connectivity/2007-08

Date: 08/02/2008

### TENDER NOTICE

Sealed tenders are invited in single bid system on behalf of ONGC Videsh Ltd for the work "DG Connectivity work at 3<sup>rd</sup> floor, Antriksh Bhavan, KG Marg, New Delhi as per the Scope of work" by Chief Engineer (E&T), Infocom Section, ONGC Videsh Ltd, New Delhi from the experienced electrical contractors of appropriate class.

Estimated Cost is **Rs. 8,05,760/-** (Rupees Eight lakhs five thousand seven Hundred sixty Only), Earnest Money Deposit is **Rs. 16,115=00** and Security Deposit is 10% of the Contract value. Blank tender document can be obtained from the office of CE (E&T), Infocom Section, ONGC Videsh Ltd, New Delhi on any working day from **08/02/2008 To 19/02/2008** up to **15:00** hrs. Tenders will be received up to **15:00 hrs** on **28/02/2008** and will be opened on **28/02/2008** at **16:00 hrs**.

Following documents as detailed in the tender set shall be required to be submitted by the tenderer **along with the tender** as prescribed, failing which the tender shall be rejected.

- (1) Earnest money deposit
- (2) Certificate of acceptance of terms & conditions in BEC clause as in Annexure -D
- (3) Valid Electrical Contractor's License.
- (4) Experience criteria in accordance with clause 2.d of BEC.
- (5) Contractor's office address in New Delhi and Telephone no.
- (6) Original Tender set duly signed on each page with price bid.
- (7) Affidavit as per Appendix -2 of Annexure B
- (8) Integrity pact as in Appendix 5 of Annexure B

Right to issue of tender documents and to reject any or all the tenders without assigning any reason thereof is reserved.

**Chief Engineer (E&T)**

# ONGC VIDESH LIMITED

6<sup>th</sup> Floor, Kailash Building,  
26 K.G.Marg, New Delhi

Office of the CE (E&T)

Tender No: OVL/7/IV/BS/DG Connectivity/2007-08



## TENDER DOCUMENT

**DG Connectivity work at 3<sup>rd</sup> floor, Antriksh Bhavan, KG Marg,  
New Delhi as per the Scope of work**

<b>ESTIMATED COST</b>	<b>:</b>	<b>Rs. 8,05,760=00</b>
<b>EARNEST MONEY</b>	<b>:</b>	<b>Rs. 16,115=00</b>
<b>SECURITY DEPOSIT</b>	<b>:</b>	<b>10% of the Contract Value</b>
<b>DATE OF SUBMISSION</b>	<b>:</b>	<b>28/02/2008 UPTO 15:00 Hrs.</b>
<b>DATE OF OPENING</b>	<b>:</b>	<b>28/02/2008 AT 16:00 Hrs.</b>
<b>PLACE OF OPENING</b>	<b>:</b>	<b>6<sup>th</sup> Floor, Kailash Building 26, KG Marg ONGC Videsh Ltd New Delhi – 110 001</b>
<b>TENDER FEE</b>	<b>:</b>	<b>-Nil-</b>

# ONGC VIDESH LIMITED

6<sup>th</sup> Floor, Kailash Building,  
26 K.G.Marg, New Delhi

Tender No. OVL/7/IV/BS/DG Connectivity/2007-08  
Office of the CE (E&T)

To,

\_\_\_\_\_  
\_\_\_\_\_

**SUBJECT: - “DG Connectivity work at 3<sup>rd</sup> floor, Antriksh Bhavan, KG Marg, New Delhi as per the Scope of work”**

Ref: - Your letter No. \_\_\_\_\_ Dated \_\_\_\_\_

Dear Sir,

With reference to above, a complete set of tender document marked as Tender Set No. \_\_\_\_\_ made in the name of \_\_\_\_\_ consisting of \_\_\_\_\_ sheets (As annexures given below) is being handed over to you / your representative.

Please acknowledge receipt of the tender document.

- |      |              |  |
|------|--------------|--|
| i)   | Annexure- A  | Tender Notice                                    |
| ii)  | Annexure- B  | Instructions to bidders ( Appendices 1 to 6)     |
|      | Appendix 1   | Certificate reg. relatives of Board of Directors |
|      | Appendix 2   | Affidavit  |
|      | Appendix 3   | Undertaking                                      |
|      | Appendix 4   | Certificate of experience                        |
|      | Appendix 5   | Business Status.                                 |
|      | Appendix 6   | Authorization letter for tender Opening          |
|      | Appendix 7   | Format for Integrity pact                        |
| iii) | Annexure –C  | General conditions of the contract               |
| iv)  | Annexure –D  | Bid Evaluation Criteria                          |
| v)   | Annexure –E  | Appendices 1 to 5                                |
|      | Appendix i   | Special Conditions of Contract                   |
|      | Appendix ii  | Special Instructions                             |
|      | Appendix iii | Price Bid Proforma                               |
|      | Appendix iv  | Scope of Work                                    |
|      | Appendix v   | List of Approved Manufacturers                   |
|      | Appendix vi  | Single Line Diagram                              |
| vi)  | Annexure – F | Proforma of Agreement                            |

Yours faithfully

Chief Engineer (E&T)  
ONGC Videsh Ltd

Date: \_\_\_\_\_

**INSTRUCTIONS**  
**TO**  
**BIDDERS**

## **INTRODUCTION AND INSTRUCTIONS TO THE TENDERER:-**

### **1. INTRODUCTION:-**

ONGC Videsh Ltd, (OVL) is engaged in the activities for exploration/ drilling / production etc. of crude oil and natural gas in various regions across the Globe and has its registered office at 6th Floor, Kailash Building, 26, KG Marg, Connaught Circus, and New Delhi. The Chief Engineer (E&T.), Infocom Section, OVL, intends to hire services of Electrical contractors for carrying out the work "DG Connectivity work at 3<sup>rd</sup> floor, Antriksh Bhavan, KG Marg, New Delhi as per the Scope of work" and accordingly invites this sealed Tender, under **single bid** system. The finalization of this tender shall be governed by the terms & conditions indicated here in under.

### **2. INSTRUCTIONS TO THE TENDERER:-**

#### **2.1 FILLING OF THE TENDERS**

- a. The tender shall be submitted only by the tenderer, in whose name the tender documents have been issued.
- b. The Tender documents shall be filled in complete in all respect and submitted together with requisite information/duly attested documents/ EMD. The tenderer should strictly adhere to formats given for submitting the Bids. It shall be free from any ambiguity, change or interlineation. However, if the tenderer wishes to furnish additional information with regard to the work, experience and credibility etc. he may do so by indicating the same on a separate sheet / page to be added duly signed by them. Each figure stated shall also be repeated in words (for the rates quoted).
- c. The tenderers are advised to meticulously peruse all the clauses, paragraphs, schedules, annexures etc. given in the tender documents.
- d. Tenderers are advised to quote their rates in format of schedule of Rates annexed.
- e. The Tenderers shall certify in prescribed format as per terms of section 297 of the companies Act 1956 as amended from time to time regarding contracts with relatives etc. of Director of OVL.
- f. The tender documents shall be signed by tenderer or by a duly authorized person of the tenderer at each page as a token of his/their acceptance of all terms & condition of the tender.
- g. All the documents furnished by the Tenderer in support of his eligibility must be signed by the authorized signatory of the tenderer and his rubber stamps should also be affixed in all these documents.
- h. The rates for the services shall be quoted in the Schedule of Rates, both in figures and words in English language and numerical only.
- i. In case of any discrepancy in the rates quoted in figures and words, the quoted rates in words shall be considered as final and authentic.
- j. Over-writing must be avoided as far as possible. In case of any over writing, the same shall be initialed in words alongside.
- k. Erasing and cutting and use of Erase-X fluid are not permitted. All additions and alteration shall be duly signed by the Tenderer.
- l. Tenderers should sign on each page of the tender document.
- m. Demand Draft / Banker's cheque towards EMD and all other relevant documents for Bid should be submitted along with the bid document, which shall be converted into SD in the case of successful party.
- n. Tenderers should sign the Integrity pact document (Annexure B, Appendix 5), confirming their acceptance of the Integrity pact. This document is mandatory for consideration of bids.
- o. All the supporting documents that are required to be submitted along with the tender should be serially numbered and enclosed here with in sequence.
- p. The tenderer should have an office in New Delhi, preferably with telephone facility. Otherwise the successful tenderer shall have to open an office at New Delhi. The contractor shall station a responsible authorized representative at this office who must be

available all time for necessary co-ordination and liaison job, as required under the contract.

## **2.2. TIME SCHEDULE:-**

The work should be completed within **45 days from the date of LOI / Work Order.**

## **2.3 STATUS OF THE TENDERER:-**

The tenderer shall clearly indicate his legal constitution and person signing shall state his capacity and also the sources of ability to bind the tenderer. The power of attorney or authorization or any other documents containing adequate proof of the signatory to bind the tenderer shall be annexed to tender. OVL may reject any tender not supported by adequate proof of signatory's authority.

## **2.4 INSTRUCTIONS FOR SUBMISSION OF TENDERS:-**

- a) The complete set of tender document (including the schedule of rates, i.e. price Bid at Appendix-iii of Annexure-"E") duly filled and each page of tender document along with its Annexures / enclosures inclusive of model contract agreement duly signed by the tenderer as token of acceptance of all terms and condition and all other necessary supporting document that are required to be submitted along with this tender as per the tender document shall be placed in envelope.
- b) The documents submitted with the bids by the tenderer must be latest valid on the date of opening of Bid.
- c) The tenderer is required to submit Affidavit in the format given at Appendix-2 of Annexure-B, along with the bid.
- d) The tenderer is required to submit undertaking in the format given at Appendix-1 of Annexure-B, along with the bid.
- e) The tenderer is required to submit the Integrity pact document in the format given in Appendix 5 of Annexure B, along with the bid.
- f) The envelope shall bear the Tender No. , Subject, Name, Address of the bidder and shall be addressed to:-

Chief Engineer (E&T)  
Infocom Section  
ONGC Videsh Ltd  
6<sup>th</sup> Floor, Kailash building  
26, KG Marg  
New Delhi – 110 001

- g) The tender should be sent either by registered post or deposited over personally so as to reach before **15:00** hrs on **28/02/2008** at the office of CE (E&T), OVL, New Delhi. Late submission on account of postal delay or any other reason will not be accepted by OVL as an excuse for consideration and the tender will be rejected.

## **2.5 SCHEDULE OF RATES:-**

The rate quoted in the "schedule of rates" by the tenderer shall be Complete, composite and firm for the entire contract period including extensions if any. The rates shall be inclusive of all expenses which mean every expense necessary for the complete execution of the job. Such expenses shall include all taxes including service tax, duties levies, fees connected with the hiring of services relating to repairs of equipments, maintenance, salaries, bonus etc. of the personal employed for the execution of the job.

## **3. GENERAL TERMS AND CONDITIONS OF TENDERS:**

OVL reserves the right to reject any or all the offers or to accept any offer without assigning any reason whatsoever. The tenderer shall not be entitled to any compensation or payment of whatsoever nature on account of such rejection.

- 3.1 OVL reserves the right to accept or all offers or split the award of work to as many contractors as deemed fit to meet the requirement.
- 3.2 In case of any dispute regarding interpretation of any clause sentence word etc., the decision of OVL shall be final and binding.
- 3.3 The tenderers are advised to physically apprise themselves with work Conditions and working areas. They are advised to get sufficient acquaintance with the actual nature of work, prevalent conditions and facilities available.
- 3.4 Canvassing in any form by the tenderer or by any other agency acting on behalf of the tenderer shall disqualify the said tenderer. The decision of the OVL in this regard shall be final and binding on the tenderer.
- 3.5 Incomplete or incorrect tender with any exception and deviation in quoting of rates etc. from given format or tender without required EMD shall be rejected at the discretion of OVL. Any conditional offer will be liable for rejection
- 3.6 OVL reserves the right to award contract at its sole discretion to one or more parties and to reject any or all the tenders received or to accept any tender without assigning any reason whatsoever.
- 3.7 All pages of bid-document, including dully filled in Annexure or any other enclosure, must be signed by the bidder or his authorized representative, as a token of acceptance of all the terms and conditions contained therein and submit the same with his offer, failing which bid shall be rejected.
- 3.8 No alterations/changes in the price bid after closing date will be taken in to account for the bid evaluation, unless specifically asked for, by OVL, as a result of discussion / clarification/ negotiation.
- 3.9 Unsolicited clarification / letters from the bidders after opening of the un-priced bid will not be considered. It may rather lead to disqualification of the bidder.
- 3.10 Bidders to note that failure to furnish all information required in the Bidding document or submission of bid not substantially responsive to the bidding document in every respect will be at the bidder's risk and might result in the rejection of its bid. OVL may not be seeking any clarification from the bidders after opening of the bid.
- 3.11 Offers of following kinds will also be rejected:-
  - a) Offers submitted without Earnest money
  - b) Telex/ Telegraphic / Fax/ e-mail / Xerox / Photocopy offers.
  - c) Offers, which do not confirm unconditional validity of the bid for 180 days from the date of opening of bid.
  - d) Offers, where prices are not firm and /or with any qualification
  - e) Offers which do not conform to OVL's price bid format
  - f) Offers, which do not conform to the deployment period indicated in the bid document.
  - g) Offers, which do not conform to the contract period indicated in the bid document.
- 3.12 The tenderer shall quote their price/rates after taking in to account the statutory or otherwise, increase in the minimum wage of his labour/contract labourers to be employed in this contract and resultant increase in the payments of PF, ESI, Bonus, Leave with Wages etc to him or this contract labourer on any ground whatsoever.

## **1. EARNEST MONEY DEPOSIT (EMD):**

- 4.1 Bid should be accompanied by EMD as per the schedule below and shall be submitted in favour of F&AO, ONGC Videsh Ltd., New Delhi either in the form of crossed Demand Draft drawn on any Nationalized/ Scheduled Bank, payable at New Delhi or Pay Order from local bank.
- 4.2 Submission of EMD of lesser amount or in the form other than as specified above shall be summarily rejected.
- 4.3 No request shall be entertained for the adjustment of EMD from any other pending bills / works / money / claims etc whatsoever, if due from OVL to the tenderer.
- 4.4 The EMD of all unsuccessful bidders shall be released / refunded without interest after expiry of validity period of Bids.
- 4.5 OVL will not pay any interest on EMD for the period of its retention by OVL.
- 4.6 **EMD shall be forfeited in the following events:-**
- i) If the tender is withdrawn during the period of validity of the offer/ Tender or any agreed extension thereof.
  - ii) If tender is modified / altered in a manner not acceptable to OVL during the validity period or any extension thereof.
  - iii) If the tenderer backs out and / or does not sign the contract Agreement after placement of LOI.
  - iv) If the information furnished in the tender is found to be materially Incorrect, false or misleading.
  - v) In any others case, specifically mentioned elsewhere in this Tender document.

## **5. BID VALIDITY:-**

The bid shall be kept valid for a period of 180 days after opening of bid and shall not be varied/modified in a manner not acceptable to OVL during this period or any extension thereof Breach of this condition will entail forfeiture of EMD in favour of OVL .

## **6. SIGNING OF CONTRACT:-**

The successful bidder will be required to sign a contract agreement on non-judicial stamp paper of requisite value at his own cost within a period of **15** days from the date of placement of LOI, The contract is signed by the parties, the terms and conditions of bid documents will govern the right and liabilities of the parties. This is without prejudice to any other right & remedies available to OVL under the contract and /or law.

\_\_\_\_\_  
(Sign of Tender issuing authority)

\_\_\_\_\_  
(Sign & Seal of Contractor)

**CONTRACTS WITH RELATIVES ETC, OF DIRECTORS OF OVL PURUSUANT TO SEC. 297  
OF THE COMPANIES ACT .1956**

The Bidders are required to certify in prescribed format as under whether he/ they is/ are related to any of the Directors of OVL in terms of Sec. 6 of the Companies Act, 1956 as amended from time to time in any of the ways mentioned in the certificate. It is clarified that any such affirmative certificate shall not, by it self prejudice consideration of the bid. This certificate must accompany the bid.

**CERTIFICATE**

This has reference to our proposed contract for **Rs. 8,05,760/-** (Rupees Eight lakhs five Thousands seven hundred sixty only) regarding work of “DG Connectivity work at 3<sup>rd</sup> floor, Antriksh Bhavan, KG Marg, New Delhi as per the Scope of work” to be entered into with ONGC Videsh Ltd (OVL). For the purpose of Section 297/299 of the Companies Act, 1956, an extract enclosed, we certify that to the best of my/our knowledge:

- (i) I am not a relative of any Director of ONGC Videsh Ltd;
- (ii) We are not a firm in which a Director of ONGC Videsh Ltd or his relative is a partner
- (iii) I am not a partner in a firm in which a Director of ONGC Videsh Ltd or his relative is a partner;
- (iv) We are not a private company in which a Director of ONGC Videsh Ltd is a Member or Director;
- (v) We are not a company in which Directors of ONGC Videsh Ltd hold more than 2% of the paid-up share capital of our company or vice-versa.

Authorized Signatory of  
The Contracting Party

Place...

Date...

**DECLARATION BY THE TENDERER REGARDING ELIGIBILITY AND ACCEPTANCE OF TERMS AND CONDITIONS OF THE TENDER DOCUMENTS**

(To be filled in and signed by the tenderer and to be submitted on non judicial paper of Rs, 20/- duly notarized by Notary Public. / First Class Magistrate along with bid)

**AFFIDAVIT**

To,  
Chief Engineer (E&T)  
Infocom Section, OVL, New Delhi.

Sir,  
Ref your Tender No: OVL/7/IV/BS/DG Connectivity/2007-08.

**I / we give following undertaking:**

1. I / we have thoroughly read and understood the terms and conditions as indicated in this tender document and accept all the terms and conditions.
2. I / we have also appraised myself / ourselves with ONGC Videsh Ltd, actual nature of work, working and other prevalent conditions.
3. I / we hereby confirm that I / we will be able to carry out the job offered by me /us as per specifications indicated in the tender after compliance of all the required formalities within the specified time at the quoted rates. If accepted by ONGC Videsh Ltd undertaking at Appendix 2 is submitted as a Commitment to provide service as mentioned in scope of work.
4. I/we hereby declare that the information furnished in the tender is correct and true to the best of my / our knowledge and belief. I /we also know and accept that if at any stage the information is found to be not correct , my / our tender shall not be considered by ONGC Videsh Ltd and EMD shall stand forfeited.
5. The acceptance of this tender by ONGC Videsh Ltd shall constitute a binding contract between me / us and ONGC Videsh Ltd.
6. I/we solemnly confirm the compliance of all the requirement / Condition of the tender documents.
7. I / we have offered our rates in the prescribed format and placed it along with the bid document.
8. I/ we hereby certify that I/we was/ were never black listed by ONGC Videsh Ltd or any of central Govt. / state Govt. / Public sector undertaking.
9. I / we have submitted the performance certificate towards the experience within ONGC Videsh Ltd or outside in the prescribed format at appendix-3 of Annexure B. That all the above documents / information furnished by me /us in my /our aforesaid tender are true and nothing has been concealed. In case any of the information is found false, or incorrect, I/we shall be liable for legal consequence besides forfeiture of the EMD/ SD. This right of OVL for forfeiture of EMD/ SD and taking legal action, criminal / civil against me /us independent of any other resource of remedy or action available to the ONGC Videsh Ltd under the enquiry contact.

Solemnly affirmed on this \_\_\_\_\_ the day of \_\_\_\_\_ 2008.

(Signature of Contractor with Seal)

**UNDERTAKING ( To be given by the contractor)**

1. I / We hereby undertake to carry out the “DG Connectivity work at 3<sup>rd</sup> floor, Antriksh Bhavan, KG Marg, New Delhi as per the Scope of work” in accordance with the terms and conditions and specification and offer to carry out the work at the quoted rates in schedule of items.
2. I / We have inspected the area covered by this contract.
3. I / We agree to abide by all terms and conditions of the contract as well as the regulations of the OVL now in force or which may come into force, during the currency of the contract.
4. I / We also undertake to carry out the work without any interference, what so ever to the operation of the OVL.
5. I / We agree for reserving the right to stop any supervising staff/ labour employed by me / us from entering in the OVL area if OVL feels that the said person is an undesirable element or is likely to create mischief. OVL will not be required to assign any reason while exercising this right and I/We shall abide by such decision of the OVL as final and binding on us.
6. I / We shall not sublet the work to any agency without the prior approval of the OVL.
7. I / We agree to execute an agreement in the Performa as may be decided by OVL and shall pay the necessary cost of stamp paper in this regard.
8. I / We also agree to undertake to carry out all types of work covered under Items of this tender as ordered from time to time by the Engineer In Charge or by his authorized representatives.
9. I / We also hereby agree and undertake to indemnify ONGC Videsh Ltd against any liability or claim to damage under workmen’s compensation.

\_\_\_\_\_  
(Sign of Tender Issuing Authority)

\_\_\_\_\_  
(Sign of Contractor with Seal)



**BUSINESS STATUS**

(The Tenderer is to furnish the following particulars)

**A. IN CASE OF AN INDIVIDUAL**

- i) Name of Business \_\_\_\_\_
- ii) Whether his business is registered. YES / NO
- iii) Date of commencement of business \_\_\_\_\_  
(Supporting documents should be enclosed)

**B. IN CASE OF PARTNERSHIP**

- i) Name of partners and their permanent address.  
1. \_\_\_\_\_  
2. \_\_\_\_\_
- ii) Whether the partnership is registered. Yes / No
- iii) Date of establishment of firm \_\_\_\_\_  
(Supporting documents should be enclose)

**C. IN CASE OF LIMITED COMPANY**

- i) Amount of paid up capital Rs. \_\_\_\_\_
- ii) Name of Directors  
1. \_\_\_\_\_  
2. \_\_\_\_\_
- iii) a) Date of registration of company \_\_\_\_\_  
b) Date of commencement of business \_\_\_\_\_  
(Supporting documents should be enclosed)

**D. IN CASE OF TRUST**

- i) Name of Executive body members and their address  
1. \_\_\_\_\_  
2. \_\_\_\_\_
- ii) Whether the Trust is registered. YES /No
- iii) Date of establishment of Trust \_\_\_\_\_  
(Supporting documents should be enclosed)

\_\_\_\_\_  
(Signature of Contractor with seal)

**AUTHORISATION LETTER FOR ATTENDING TENDER OPENING**

No.

Date:

To,

The Chief Engineer (E&T)  
Infocom Section  
ONGC Videsh Ltd., New Delhi

Subject: Tender No. OVL/7/IV/BS/DG Connectivity/2007-08

due on

Sir,

Mr..... has been authorized to be present at the time of opening of above tender due on \_\_\_\_\_ at 15:00 on my/our behalf.

Yours faithfully

Signature of Bidder

Copy to: Mr.....for information and for production before the Chief Engineer (E&T) at the time of opening of bids.

\_\_\_\_\_  
(Signature of Contractor with seal)

## **Format for Integrity pact**

Between ONGC Videsh Ltd., (OVL) hereinafter referred to as “The Principal”, and  
 ..... hereinafter referred to as “The Bidder/  
 Contractor”

### **Preamble**

The Principal intends to award, under laid down organizational procedures, contract/s for -----  
 ----- The Principal values full compliance with all relevant laws and regulations, and the principles of economic use of resources, and of fairness and transparency in its relations with its Bidder/s and Contractor/s. In order to achieve these goals, the Principal cooperates with the renowned international Non-Governmental Organisation “Transparency International” (TI). Following TI’s national and international experience, the Principal will appoint an external independent Monitor who will monitor the tender process and the execution of the contract for compliance with the principles mentioned above.

#### **Section 1 – Commitments of the Principal**

- (1) The Principal commits itself to take all measures necessary to prevent corruption and to observe the following principles:-
  - (1) No employee of the Principal, personally or through family members, will in connection with the tender for , or the execution of a contract, demand, take a promise for or accept, for him/herself or third person, any material or immaterial benefit which he/she is not legally entitled to.
  - (2) The Principal will, during the tender process treat all Bidders with equity and reason. The Principal will in particular, before and during the tender process, provide to all Bidders the same information and will not provide to any Bidder confidential / additional information through which the Bidder could obtain an advantage in relation to the tender process or the contract execution.
  - (3) The Principal will exclude from the process all known prejudiced persons.
- (2) If the Principal obtains information on the conduct of any of its employees which is a criminal offence under the relevant Anti-Corruption Laws of India, or if there be a substantive suspicion in this regard, the Principal will inform its Vigilance Office and in addition can initiate disciplinary actions.

#### **Section 2 – Commitments of the Bidder/ contractor**

- (1) The Bidder / Contractor commit itself to take all measures necessary to prevent corruption. He commits himself to observe the following principles during his participation in the tender process and during the contract execution.
  1. The Bidder / Contractor will not, directly or through any other person or firm, offer, promise or give to any of the Principal’s employees involved in the tender process or the execution of the contract or to any third person any material or immaterial benefit which he/she is not legally entitled to, in order to obtain in exchange any advantage of any kind whatsoever during the tender process or during the execution of the contract.
  2. The Bidder / Contractor will not enter with other Bidders into any undisclosed agreement or understanding, whether formal or informal. This applies in particular to prices, specifications, certifications, subsidiary contracts, submission or non-submission of bids or any other actions to restrict competitiveness or to introduce cartelisation in the bidding process.
  3. The Bidder / Contractor will not commit any offence under the relevant Anti-corruption Laws of India; further the Bidder / Contractor will not use improperly, for purposes of

competition or personal gain, or pass on to others, any information or document provided by the Principal as part of the business relationship, regarding plans, technical proposals and business details, including information contained or transmitted electronically.

4. The Bidder / Contractor will, when presenting his bid, disclose any and all payments he has made, is committed to or intends to make to agents, brokers or any other intermediaries in connection with the award of the contract.
- (2) The Bidder / Contractor will not instigate third persons to commit offences outlined above or be an accessory to such offences.

### **Section 3- Disqualification from tender process and exclusion from future contracts**

If the Bidder, before contract award has committed a transgression through a violation of Section 2 or in any other form such as to put his reliability or credibility as Bidder into question, the Principal is entitled to disqualify the Bidder from the tender process or to terminate the contract, if already signed, for such reason.

- (1) If the Bidder / Contractor has committed a transgression through a violation of Section 2 such as to put his reliability or credibility into question, the Principal is entitled also to exclude the Bidder / Contractor from future contract award processes. The imposition and duration of the exclusion will be determined by the severity of the transgression. The severity will be determined by the circumstances of the case, in particular the number of transgressions, the position of the transgressors within the company hierarchy of the Bidder and the amount of the damage. The exclusion will be imposed for a minimum of 6 months and maximum of 3 years.
- (2) The Bidder accepts and undertakes to respect and uphold the Principal's absolute right to resort to and impose such exclusion and further accepts and undertakes not to challenge or question such exclusion on any ground, including the lack of any hearing before the decision to resort to such exclusion is taken. This undertaking is given freely and after obtaining independent legal advice.
- (3) If the Bidder / Contractor can prove that he has restored / recouped the damage caused by him and has installed a suitable corruption prevention system, the Principal may revoke the exclusion prematurely.
- (4) A transgression is considered to have occurred if in light of available evidence no reasonable doubt is possible.

### **Section 4 – Compensation for Damages**

- (1) If the Principal has disqualified the Bidder from the tender process prior to the award according to Section 3, the Principal is entitled to demand and recover from the Bidder liquidated damages equivalent to 3 % of the value of the offer or the amount equivalent to Earnest Money Deposit / Bid Security , whichever is higher.
- (2) If the Principal has terminated the contract according to Section 3, or if the Principal is entitled to terminate the contract according to Section 3, the Principal shall be entitled to demand and recover from the Contractor liquidated damages equivalent to 5 % of the contract value or the amount equivalent to Security Deposit / Performance Bank Guarantee, whichever is higher.
- (3) The bidder agrees and undertakes to pay the said amounts without protest or demur subject only to condition that if the Bidder / Contractor can prove and establish that the exclusion of the Bidder from the tender process or the termination of the contract after the

contract award has caused no damage or less damage than the amount of the liquidated damages, the Bidder / Contractor shall compensate the Principal only to the extent of the damage in the amount proved.

#### **Section 5 – Previous transgression**

- (1) The Bidder declares that no previous transgressions occurred in the last 3 years with any other Company in any country conforming to the TI approach or with any other Public Sector Enterprise in India that could justify his exclusion from the tender process.
- (2) If the Bidder makes incorrect statement on this subject, he can be disqualified from the tender process or the contract, if already awarded, can be terminated for such reason.

#### **Section 6 – Equal treatment of all Bidders / Contractors / Subcontractors**

- (1) The Bidder / Contractor undertake to demand from all subcontractors a Commitment in conformity with this Integrity Pact, and to submit it to the Principal before contract signing.
- (2) The Principal will enter into agreements with identical conditions as this one with all Bidders, Contractors and Subcontractors.
- (3) The Principal will disqualify from the tender process all bidders who do not sign this Pact or violate its provisions.

#### **Section 7 – Criminal charges against violating Bidders / Contractors / Subcontractors**

If the Principal obtains knowledge of conduct of a Bidder, Contractor or Subcontractor, or of an employee or a representative or an associate of a Bidder, Contractor or Subcontractor which constitutes corruption, or if the Principal has substantive suspicion in this regard, the Principal will inform the Vigilance Office.

#### **Section 8 – External Independent Monitor / Monitors (three in number depending on the size of the contract) (to be decided by the Chairperson of the Principal)**

- (1) The Principal appoints competent and credible external independent Monitor for this Pact. The task of the Monitor is to review independently and objectively, whether and to what extent the parties comply with the obligations under this agreement.
- (2) The Monitor is not subject to instructions by the representatives of the parties and performs his functions neutrally and independently. He reports to the Chairperson of the Board of the Principal.
- (3) The Contractor accepts that the Monitor has the right to access without restriction to all Project documentation of the Principal including that provided by the Contractor. The Contractor will also grant the Monitor, upon his request and demonstration of a valid interest, unrestricted and unconditional access to his project documentation. The same is applicable to Subcontractors. The Monitor is under contractual obligation to treat the information and documents of the Bidder / Contractor / Subcontractor with confidentiality.
- (4) The Principal will provide to the Monitor sufficient information about all meetings among the parties related to the Project provided such meetings could have an impact on the contractual relations between the Principal and the Contractor. The parties offer to the Monitor the option to participate in such meetings.

- (5) As soon as the Monitor notices, or believes to notice, a violation of this agreement, he will so inform the Management of the Principal and request the Management to discontinue or heal the violation, or to take other relevant action. The monitor can in this regard submit non-binding recommendations. Beyond this, the Monitor has no right to demand from the parties that they act in a specific manner, refrain from action or tolerate action.
- (6) The Monitor will submit a written report to the Chairperson of the Board of the Principal within 8 to 10 weeks from the date of reference or intimation to him by the 'Principal' and, should the occasion arise, submit proposals for correcting problematic situations.
- (7) Monitor shall be entitled to compensation on the same terms as being extended to / provided to Outside Expert Committee members / Chairman as prevailing with Principal.
- (8) If the Monitor has reported to the Chairperson of the Board a substantiated suspicion of an offence under relevant Anti-Corruption Laws of India, and the Chairperson has not, within reasonable time, taken visible action to proceed against such offence or reported it to the Vigilance Office, the Monitor may also transmit this information directly to the Central Vigilance Commissioner, Government of India.
- (9) The word 'Monitor' would include both singular and plural.

**Section 9 – Pact Duration**

This Pact begins when both parties have legally signed it. It expires for the Contractor 12 months after the last payment under the respective contract, and for all other Bidders 6 months after the contract has been awarded.

If any claim is made / lodged during this time, the same shall be binding and continue to be valid despite the lapse of this pact as specified above, unless it is discharged / determined by Chairperson of the Principal.

**Section 10 – Other provisions**

- (1) This agreement is subject to Indian Law. Place of performance and jurisdiction is the Registered Office of the Principal, i.e. New Delhi.
- (2) Changes and supplements as well as termination notices need to be made in writing. Side agreements have not been made.
- (3) If the Contractor is a partnership or a consortium, this agreement must be signed by all partners or consortium members.
- (4) Should one or several provisions of this agreement turn out to be invalid, the remainder of this agreement remains valid. In this case, the parties will strive to come to an agreement to their original intentions.

-----  
For the Principal

-----  
For the Bidder / Contractor

Place -----

Witness 1 : -----.

Date -----

Witness 2 : -----

**GENERAL  
CONDITIONS  
OF CONTRACT**

## MODEL CONTRACT AND GENERAL CONTRACT CONDITIONS

This CONTRACT is made and entered into on this .....day of ...Two thousand and six by and between ONGC Videsh Ltd, having its registered office at 6<sup>th</sup> Floor, Kailash Buiding, 26, KG Marg, Connaught Circus, New Delhi- 110 001, India (hereinafter referred to as "OVL" which expression shall include its successors, administrators, executors and assignees) on the one part and M/s ....., a company registered under the companies Act with its Registered office at ..... referred to as the "CONTRACTOR" (which expression shall include its successors, administrators, executors and permitted assignees) on the other part.

Whereas OVL is desirous of ..... (Description of services) for carrying out OVL's operations conforming to specifications as set forth in the Scope of Work at Annexure-III of this agreement.

And Whereas the CONTRACTOR represents that it has the necessary experience for carrying out OVL's operations as referred to herein and has submitted a bid for providing the required services against OVL's Tender No..... all in accordance with the terms and conditions set forth herein and any other reasonable requirements of the OVL from time to time.

And Whereas OVL has accepted the bid of the CONTRACTOR and has placed Fax order / Letter of Intent /Notification of Award vide its letter ..... Dated.... On the CONTRACTOR.

And Whereas the contractor has deposited a sum of Rs. \_\_\_\_\_ in the shape of bank draft / banker's cheque No.\_\_\_\_\_ dated \_\_\_\_\_ Drawn on \_\_\_\_\_ as earnest money pledged to the Finance and accounts officer, ONGC Videsh Ltd, New Delhi for due and faithful performance of the contract and further agreed to execute the said work according to the Conditions of Contract, Specifications, Schedule of work, List of the materials to be supplied, Servicing & Overhauling schedules, items of works bill of quantities and tendered rates ( hereinafter referred to as "The Documents" )

Now it is hereby agreed to by and between the parties as under:

1. **DEFINITIONS:**
  - 1.0 Unless inconsistent with or otherwise indicated by the context, the following terms stipulated in this CONTRACT shall have the meaning as defined hereunder.
    - 1.1 **CONTRACT**  
Shall mean a written CONTRACT signed between OVL and the CONTRACTOR (the successful bidder) including subsequent amendments to the CONTRACT in writing thereto.
    - 1.2 **OVL:**  
Shall mean ONGC Videsh Ltd., India and shall include its legal representatives, successors and permitted assignees.
    - 1.3 **SITE**  
Shall mean the place in which the operations/services are to be carried out or places approved by the OVL for the purposes of the CONTRACT together with any other places designated in the CONTRACT as forming part of the site.
    - 1.4 **OVL'S SITE REPRESENTATIVE/ENGINEER**  
Shall mean the person or the persons appointed by OVL from time to time to act on its behalf at the site for overall co-ordination, supervision and project management at site.
    - 1.5 **CONTRACTOR:**  
Shall mean any person/ persons/ firm/ company etc. to whom work has been awarded and whose bid has been accepted by OVL and shall include its authorized representatives, successors and permitted assignees.

- 1.6 **CONTRACTOR'S REPRESENTATIVE**  
Shall mean such person/or persons duly appointed representative at the site and base as the CONTRACTOR may designate in writing to the OVL as having authority to act for the CONTRACTOR in matters affecting the work and to provide the requisite services.
- 1.7 **CONTRACT PRICE**  
Shall mean the sum accepted or the sum calculated in accordance with the rates accepted by OVL and amendments thereof, and shall include all fees, registration and other charges paid to statutory authorities without any liability on OVL for any of these charges. The prices will remain firm during currency of the CONTRACT.
- 1.8 **DAY**  
Shall mean a calendar day of twenty-four (24) consecutive hours beginning at 0000 hours with reference to local time at the site.
- 1.9 **MATERIALS / SERVICE**  
Shall mean and include any material which CONTRACTOR is required to provide to the OVL for/under the CONTRACT and amendments thereto.
- 1.10 **WORKS / OPERATIONS:**  
Shall mean all work to be performed by the CONTRACTOR as specified in the Scope of Work under this CONTRACT.
- 1.11 **GUARANTEE**  
Shall mean the period and other conditions governing the warranty/guarantee of the works as provided in the CONTRACT.
- 1.12 **MOBILISATION**  
Shall mean rendering the equipment fully manned and equipped as per CONTRACT and ready to begin work at site designated by OVL and OVL's acceptance thereafter. The date and time of OVL's acceptance of service to be provided by contractor will be treated as the date and time of mobilization.
- 1.13 **DEMOBILISATION**  
Shall mean the removal of all things forming part of the mobilization from the site of OVL. The date and time of OFFHIRE service shall be treated as the date and time of demobilization.
- 1.14 **DRAWINGS**  
Shall mean and include all Engineering sketches, general arrangements/ layout drawings, sectional plans, all elevations, etc. related to the CONTRACT together with modification and revision thereto.
- 1.15 **SPECIFICATIONS**  
Shall mean and include detailed description, statements to technical data, performance characteristics, and standards (Indian as well as International) as applicable and as specified in the CONTRACT.
- 1.16 **INSPECTORS**  
Shall mean any person or outside Agency nominated by OVL to inspect equipment, materials and services, if any, in the CONTRACT stage wise as well as final as per the terms of the **CONTRACT**.
- 1.17 **TESTS**  
Shall mean such process or processes to be carried out by the CONTRACTOR as are prescribed in the CONTRACT considered necessary by OVL or their representative in CONTRACT to ascertain quality, workmanship, performance and efficiency of equipment or services thereof.

1.18 **FACILITY**

Shall mean all property of the OVL owned or hired by OVL.

1.19 **THIRD PARTY**

Shall mean any group, corporation, person or persons who may be engaged in activity associated with the work specified but who shall remain at an arm's length from the work and who shall not have a direct responsibility or authority under the terms of this CONTRACT.

1.20 **APPROVAL**

Shall mean and include the written consent duly signed by OVL or their representative in respect of all documents, drawings or other particulars in relation to the CONTRACT

2.0 **SCOPE OF WORK / CONTRACT**

Scope of the CONTRACT shall be as defined in the CONTRACT, specifications, drawings and annexures thereto at Annexure- E, Appendix 4,5,6.

3.0 **DURATION OF THE CONTRACT**

This CONTRACT shall remain valid for a period of ..... days from ..... (The date and time of commencement).

4.0 **NOTICES AND ADDRESSES**

For the purposes of this CONTRACT, the addresses of the parties will be as follows and all correspondence and notices in relations to the present CONTRACT sent to the parties at the addresses mentioned below shall be deemed to be sufficient service of notice on the parties. All such notices as will as reports, invoices and other relevant material shall be addressed to the parties as per the address given below:

4.1 **ONGC Videsh Ltd**

**For CONTRACT related communication, operations, reports and payments**

The Chief Engineer (E&T)  
Infocom Section  
6<sup>th</sup> Floor, Kailash Building  
26, KG Marg  
New Delhi - 110001

4.2 **CONTRACTOR'S REGISTERED OFFICE AND ADDRESS**

.....  
.....  
Fax:.....

5.0 **DUTIES AND POWER /AUTHORITY**

5.1 The duties and authorities of the OVL's site representative are to act on behalf of the OVL for:

- (i) Overall supervision, co-ordination and Project Management at site
- (ii) Proper utilization of equipment and services.
- (iii) Monitoring of performance and progress
- (iv) Commenting/ countersigning on reports made by the CONTRACTOR's representative at site in respect of works, receipts, and consumption etc. after satisfying himself with the facts of the respective cases.
- (v) He shall have the authority, but not obligation at all times and any time to inspect/test/examine/ verify any equipment machinery, instruments, tools, materials, personnel, procedures and reports etc. directly or indirectly pertaining to the

execution of the work. However this shall not construe to imply an acceptance by the inspector. Hence, the overall responsibility of quality of work shall rest solely with the CONTRACTOR.

- (vi) Each and every document emerging from site in support of any claim by the contractor has to have the countersignature/ comments of the OVL's representative/engineer without which no claim will be entertained by the OVL.

5.2 The duties and authorities of the **Contractor's representative are:**

- (i) The Contractor's representative shall have all the powers requisite for the performance of the works.
- (ii) He shall liaise with OVL's representative for the proper co-ordination and timely completion of the works and on any matter pertaining to the works.
- (iii) He will extend full co-operation to OVL's representative/inspector in the manner required by them for supervision/inspection/observation of equipment, material, procedures, performance, reports and records pertaining to works.
- (iv) To have complete charge of CONTRACTOR's personnel engaged in the performance of the work and to ensure compliance of rules and regulations and safety practice.

6. **CONTRACT DOCUMENT**

6.1 **Governing language**

The governing language for the CONTRACT shall be English. All CONTRACT documents and all correspondence and communication to be given and all other documentation to be prepared and supplied under the CONTRACT shall be written in English and the CONTRACT shall be construed and interpreted in accordance with English language.

6.2 **Entire Agreement**

The CONTRACT constitutes the entire agreement between the OVL and the CONTRACTOR with respect to the subject matter of the CONTRACT and supersedes all communication, negotiations and agreement (whether written or oral) of the parties with respect thereto made prior to the date of this agreement.

- 6.3 Save where the context otherwise requires, words imparting singular number shall include the plural and vice versa and words imparting neutral gender shall include masculine or feminine gender and vice versa.

6.4 **Modification in CONTRACT**

All modifications leading to changes in the CONTRACT with respect to technical and/or commercial aspects, including terms of delivery, shall be considered valid only when accepted in writing by OVL by issuing amendment to the **CONTRACT**. OVL shall not be bound by any printed conditions, provisions in the CONTRACT's BID, forms of acknowledgement of **CONTRACT**, invoice, packing list and other documents which purport to impose any condition at variance with or supplement to **CONTRACT**.

6.5 **Assignment**

The CONTRACTOR shall not, save with the previous consent in writing of the OVL, sublet/SUB-CONTRACT, transfer or assign the CONTRACT or any part thereof in any manner whatsoever. However, such consent shall not relieve the CONTRACTOR from any obligation, duty or responsibility under the CONTRACT and CONTRACTOR shall be fully responsible for the services hereunder and for the execution and performance of the CONTRACT.

6.6 **Waivers and amendments:**

- a) Waivers: - It is fully understood and agreed that none of the terms and conditions of this CONTRACT shall be deemed waived by either party unless such waiver is executed in writing only by the duly authorized agents or representative of both the parties. The failure of either party to execute any right shall not act as a waiver of such right by such party.

- b) Amendments: - It is agreed that CONTRACTOR shall carry out work in accordance with the completion program to be furnished by the OVL which may be amended from time to time by reasonable modifications as OVL sees fit.

## **7.0 TERMS OF PAYMENT**

- 7.1 OVL shall pay to CONTRACTOR after the successful completion, testing and taking over of work to the complete satisfaction of the Engineer In-charge. No advance payment shall be made under any circumstances.
- 7.2 The bill invoice in triplicate shall be submitted by the contractor to the Chief Engineer (E&T), Infocomm Section, ONGC Videsh Ltd, New Delhi. Payment shall be made within 15 days from the date of receipt of invoice at the above office, if found in order.

## **8.0 CLAIMS, TAXES & DUTIES, FEES AND ACCOUNTING :**

### **8.1 CLAIMS:-**

CONTRACTOR agrees to pay all claims, taxes and fees for equipment, labour, materials, services and supplies to be furnished by it hereunder and agrees to allow no lien or charge resulting from such claims to be fixed upon any property of OVL. OVL may, at its option, pay and discharge any liens or overdue charges for CONTRACTOR's equipment, labour, materials, services and supplies under this CONTRACT and may thereupon deduct the amount or amounts so paid from any sum due, or thereafter become due, to CONTRACTOR hereunder.

### **8.2 NOTICE OF CLAIMS:-**

CONTRACTOR or OVL, as the case may be, shall promptly give the other, notice in writing of any claim made or proceeding commenced for which that party is entitled to indemnification under the CONTRACT. Each party shall confer with the other concerning the defense of any such claims or proceeding, shall permit the other to be represented by counsel in defense thereof, and shall not effect settlement of or compromise any such claim or proceeding without the other's written consent.

### **8.3 TAXES:-**

CONTRACTOR, unless specified otherwise in the CONTRACT, shall bear all tax liabilities, duties, Govt. levies etc. including customs duty, Corporate and personnel taxes levied or imposed on the CONTRACTOR on account of payments received by it from the OVL for the work done under this CONTRACT. It shall be the responsibility of the CONTRACTOR to submit to the concerned Indian authorities, the returns and all other concerned documents required for this purpose and to comply in all respects with the requirements of the laws in this regard, in time.

### **8.4 PERSONNEL TAXES:-**

The CONTRACTOR shall bear all personnel taxes levied or imposed on its personnel, SUB-CONTRACTOR's personnel, vendors, consultants etc. on account of payment received under this CONTRACT.

### **8.5 CORPORATE TAXES:-**

The CONTRACTOR shall bear all Corporate taxes, levied or imposed on the CONTRACTOR on account of payments received by it from the OVL for the work done under this CONTRACT.

- 8.6 If it is so required by the applicable laws in force at the time of payment, the OVL shall withhold from the amount due to the CONTRACTOR and pay to the Indian Tax authorities any tax levied or assessed on account of the CONTRACTOR's operations pursuant to this CONTRACT.

- 8.7 It is noted that CONTRACT u/s 195(2) of the Income Tax Act, 1961 for the purpose of deduction of tax at source will be obtained by OVL from the Dy. Commissioner of Income Tax(Asst.), Special Range-I, Dehradun India.

- 8.8 For the lapse, if any on the part of the CONTRACTOR and consequential penal action taken by the Tax department, the OVL shall not take any responsibility whether financial or otherwise.

**9.0 PERFORMANCE:-**

The CONTRACTOR shall undertake to perform all services under this CONTRACT with all-reasonable skill, diligence and care in accordance with sound industry practice to the satisfaction of the OVL and accept full responsibility for the satisfactory quality of such services as performed by them. Any defect, deficiencies noticed in the CONTRACTOR's service will be promptly remedied by the CONTRACTOR within 2 days upon the receipt of written notice from the OVL to improve their performance failing which the OVL may terminate the CONTRACT by giving the CONTRACTOR 30 (thirty) day's written notice.

**10.0 DISCIPLINE:-**

CONTRACTOR shall carry out operations hereunder with due diligence and in a safe and workman like manner according to good international oilfield practice. CONTRACTOR shall maintain strict discipline and good CONTRACT among its employees and its SUB-CONTRACTOR's employees and shall abide by and conform to all rules and regulations promulgated by the OVL governing the operations. Should OVL feel that the conduct of any of CONTRACTOR/SUB-CONTRACTOR's employees is detrimental to OVL's interest, the OVL shall have the unqualified right to request for the removal of such employee either for incompetence, unreliability, misbehavior, security reasons etc. while on or off the job. The CONTRACTOR shall comply with any such request to remove such personnel at CONTRACTOR's expense unconditionally.

**11. SAFETY AND LABOUR LAWS:-**

CONTRACTOR shall comply with the provision of all laws including Labour Laws, rules, regulations and notifications issued thereunder from time to time. All safety and labour laws enforced by statutory agencies and by OVL shall be applicable in the performance of this CONTRACT and CONTRACTOR shall abide by these laws.

CONTRACTOR shall take all measures necessary or proper to protect the personnel, work and facilities and shall observe all reasonable safety rules and instructions. No smoking shall be permitted out side the living quarters, and welding jobs will be carried out with full safety precautions. OVL's employee also shall comply with safety procedures/policy.

The CONTRACTOR shall report as soon as possible any evidence which may indicate or is likely to lead to an abnormal or dangerous situation and shall take all necessary emergency control steps to avoid such abnormal situations.

**12. SECRECY:-**

CONTRACTOR shall during the tenure of the CONTRACT and at anytime thereafter maintain in the strictest confidence all information relating to the work and shall not, unless so authorised in writing by OVL, divulge or grant access to any information about the work or its results and shall prevent anyone becoming acquainted with either through CONTRACTOR or its personnel or authorised SUB-Contractors or agents. CONTRACTOR shall not avail of the information obtained in the course of work hereunder in any manner, whatsoever, nor shall CONTRACTOR divulge any information about the location of the work area of part thereof. CONTRACTOR shall not also destroy any report, note and technical data relating to the operation/ work and not required by the OVL. The obligation is continuing one and shall survive after the completion/ termination of this agreement.

**13. STATUTORY REQUIREMENTS:-**

During the tenure of this CONTRACT nothing shall be done by the CONTRACTOR in contravention of any law, act and/or rules/regulations, there under or any amendment thereof governing interalia customs stowaways, foreign exchange etc.

14. **INSURANCE:-**

A) CONTRACTOR shall, at his own expense, arrange appropriate comprehensive insurance to cover all risks assumed by the CONTRACTOR under this CONTRACT in respect of its personnel deputed under this CONTRACT as well as CONTRACTOR's equipment, tools and any other belongings of the CONTRACTOR or their personnel during the entire period of their engagement in connection with this CONTRACT. OVL will have no liability on this account;

B) Insurance by CONTRACTOR for OVL's existing property:-

CONTRACTOR shall take out insurance policies against all risks of loss or damage caused to OVL's property comprising but not limited to live wells, fixed and mobile offshore drilling units, platforms, pipelines, SBMs vessels crafts, ships and tenders and other equipments for property owned or hired by OVL and the works and part of the works taken over by OVL however, caused by the CONTRACTOR or his authorized representatives, agent or sub-Contractors up to the deductible amount under the OVL's package policy of US\$ \_\_\_\_\_ per occurrence.

Notwithstanding anything contained in any provision of this CONTRACT, save as specified above in this Clause OVL shall defend, indemnify and hold Contractor harmless from and against any losses, damages, cost or claims relating to OVL's existing property except in case of gross negligence or willful misconduct of the Contractor, its sub-contractor their agents or employees, in which case the Contractor shall be liable to bear any loss or damage occurring to the Property of the OVL as a result of its gross negligence or willful misconduct, provided however, that such liability shall be limited to 100% of the CONTRACT Price.

"Gross Negligence" means: any act or failure to act (whether sole, joint or concurrent) by a person or entity which was intended to cause, or which was in reckless disregard of or wanton indifference to, avoidable and harmful consequences such person or entity knew, or should have known, would result from such act or failure to act. Notwithstanding the foregoing, Gross negligence shall not include any action taken in good faith for the safeguard of life or property, "willful misconduct" means: "intentional disregard of good and prudent standards of performance or proper conduct under the CONTRACT with knowledge that it is likely to result in any injury to any person or persons or loss or damage of property.

C) Waiver of subrogation: All insurance policies of the CONTRACTOR with respect to the operations conducted hereunder as set forth in clause 13 hereof, shall be endorsed by the underwriter in accordance with the following policy wording:-

"The insurers hereby waive their rights of subrogation against any individual, OVL, affiliates or assignees for whom or with whom the assured may be operating to the extent of the Contractual indemnities undertaken by the CONTRACTOR".

D) Certificate of Insurance: Before commencing performance of the CONTRACT, CONTRACTOR shall upon request furnish OVL with certificates of insurance indicating (1) kinds and amounts of insurance as required herein (2) insurance OVL or companies carrying the aforesaid coverage (3) effective and expiry dates of policies (4) that OVL shall be given thirty (30) days written advance notice of any material change in the policy (5) waiver of subrogation endorsement has been attached to all policies and (6) the territorial limits of all policies. If any of the above policy expire or/ are cancelled during the term of this CONTRACT and CONTRACTOR fails for any reason to renew such policies, then OVL may replace same and charge the cost thereof to CONTRACTOR. Should there be lapse in any insurance required to be carried out by CONTRACTOR hereunder for any reason, losses resulting there from shall be to the sole account of the CONTRACTOR. Such insurance shall be effected within Insurance Company incorporated and registered in India or jointly with a Company of International repute and an Insurance Company incorporated and registered in India.

- E) Deductible:- That portion of any loss not covered by insurance provided for in this article solely by reason of deductible provision in such insurance policies shall be to the account of the CONTRACTOR.
- F) CONTRACTOR shall require all of its SUB-Contractors to provide such of the foregoing insurance cover as the CONTRACTOR is obligated to provide under this CONTRACT.

## **15. INDEMNITY AGREEMENT:**

### **15.1 INDEMNITY BY CONTRACTOR:**

CONTRACTOR shall indemnify and keep indemnified OVL, its contractors (other than the CONTRACTOR) and/or sub-contractors and its/their employees from all actions, proceedings suits, claims, demands, liabilities, damages, losses, costs, charges, expenses (including without limitation, wreck or debris, removal costs, where wreck or debris removal is ordered by a competent authority) judgments and fines arising out of or in the course of or caused by the execution of work under the CONTRACT or other obligations hereunder directly or indirectly associated herewith including but not limited to

- a) Personal injury, illness or death of :
- i) Any of Contractor's or subcontractor's personnel (even if caused by or contributed to by the negligence or fault of OVL); and
  - ii) Subject to clause 17.2 (a) (I) any other person to the extent the injury, illness or death is caused by the negligence or fault of the Contractor or Contractor's personnel or subcontractors or subcontractor's personnel and
- b) loss or damage to :
- i) Any property owned, hired or supplied by Contractor or Contractor's personnel or subcontractors or subcontractor's personnel including Constructional Plant (even if caused by, or contributed to by, the negligence or fault of OVL); or
  - ii) Subject to clause 17.2 (b) (I) any other property to the extent the loss or damage is caused by the negligence or fault of the Contractor or Contractor's personnel or subcontractors or subcontractor's personnel.

### **15.2 INDEMNITY BY OVL**

OVL shall indemnify and keep indemnified CONTRACTOR (which expression in this clause includes, unless the context otherwise requires. Subcontractors of any tier and their employees) from all actions, proceedings, suits, claims, demands, liabilities, damages, losses, costs, charges, expenses and fines arising from :

- a) Personal injury, illness or death of
- i) Any employee of the OVL (even if caused by or contributed to by the negligence or fault of Contractor);
  - ii) Subject to clause 17.1 (a) (I) any other person to the extent that the injury, illness or death is caused by the negligence or fault of OVL ; and
- b) Any loss or damage to:
- i) Any property owned, hired or supplied by OVL (even if caused by or contributed to by the negligence or fault of Contractor); except to the extent that such property is in the care or custody of Contractor in connection with the work under the Contract.
  - ii) Subject to clause 17.1 (b) (I) any loss or damage to any other property to the extent the loss or damage is caused by the negligence or fault of OVL.

## **16. TERMINATION**

### **16.1 Termination on expiry of the CONTRACT**

This Agreement shall be deemed to have been automatically terminated on the expiry of the CONTRACT period unless the OVL has exercised its option to extend this CONTRACT in accordance with the provisions, if any, of this CONTRACT.

**16.2 Termination on account of force majeure**

Either party shall have the right to terminate this CONTRACT on account of Force Majeure, as set forth in clause 21

**16.3 Termination on account of insolvency**

In the event the CONTRACTOR or its collaborator at any time during the term of this Agreement becomes insolvent or makes a voluntary assignment of its assets for the benefit of creditors or is adjudged bankrupt, then the OVL shall, by a notice in Writing have the right to terminate this CONTRACT and all the CONTRACTOR's rights and privileges hereunder, shall stand terminated forthwith.

**16.4 Termination for unsatisfactory performance**

If OVL considers that the performance of the CONTRACTOR is unsatisfactory or, not up to the expected standard, then OVL shall notify the CONTRACTOR in writing and specify in detail the cause of such dissatisfaction. OVL shall have the option to terminate this Agreement by giving 30 days notice in writing to the CONTRACTOR, if, CONTRACTOR fails to comply with the requisitions contained in the said written notice issued by the OVL.

**16.5 Termination for delay in mobilization**

Successful bidder shall be required to mobilise complete equipment alongwith crew (only crew in case of Operation and Maintenance Contracts) for commencement of services at the specified site within a maximum of 7 days from the date of Fax order / LOI / NOA. If the CONTRACTOR (successful bidder) fails to mobilise as above, the CONTRACT shall automatically stand terminated unless OVL has extended the mobilisation period with levy of Liquidated Damages, as per Clause ... of the Special Conditions of Contract.

**16.6 Consequences of termination**

In all cases of termination herein set forth, there will be no obligation of OVL to pay. Notwithstanding the termination of this Agreement, the parties shall continue to be bound by the provisions of this Agreement that reasonably require some action or forbearance after such termination.

**In case of termination of CONTRACT herein set forth except under 16.1 and 16.2, the CONTRACTOR shall be put on holiday [i.e. neither any enquiry will be issued to the party by OVL against any type of tender nor their offer will be considered by OVL against any ongoing tender(s) where contract between OVL and that particular CONTRACTOR (as a bidder) has not been finalized] for two years from the date of termination by OVL to such CONTRACTOR.**

**17. SEVERABILITY:**

Should any provision of this agreement be found to be invalid, illegal or otherwise not enforceable by any court of law, such finding shall not affect the remaining provisions hereto and they shall remain binding on the parties hereto.

**18. CONSEQUENTIAL DAMAGES:**

Notwithstanding either party's fault, neither party shall be liable to the other party in respect of any consequential damages whatsoever. The term "Consequential damages" as used herein shall include without limitations to the meaning, loss of profit, production, business opportunities or use of assets.

**19. CHANGE IN LAW:**

In the event of any change or amendment of any Act or law, Rules or Regulations of Govt. of India or Public Body or any change in the interpretation or enforcement of any said Act or law, rules or regulations by Indian Govt. or public body which becomes effective after the date as advised by the OVL for submission of final price bid for this CONTRACT and which results in increased cost of the works under the CONTRACT through increased liability of taxes, (other than personnel and Corporate taxes), duties, the CONTRACTOR shall be indemnified for any such increased cost by the OVL subject to the production of documentary proof to the satisfaction of the OVL to the extent which is attributable to such change or amendment as mentioned above.

Similarly, if any change or amendment of any Act or Law including Indian Income Tax Act, Rules or regulations of any Govt. or public body or any change in the interpretation or enforcement of any said Act or Law, rules or regulations by Indian Govt. or public body becomes effective after the date as advised by the OVL for submission of final price bid of this CONTRACT and which results in any decrease in the cost of the project through reduced liability of taxes, (other than personnel and Corporate taxes) duties, the CONTRACTOR shall pass on the benefits of such reduced cost, taxes or duties to the OVL.

Notwithstanding the above mentioned provisions, OVL shall not bear any liability in respect of (I) Personnel taxes on the employees of CONTRACTOR and the employees of all its SUB-Contractors etc. (ii) Corporate taxes in respect of the CONTRACTOR and its SUB-Contractors etc.

**20. LIABILITY OF THE GOVERNMENT OF INDIA:-**

It is expressly understood and agreed by and between the CONTRACTOR and OVL (the Indian PSU), that OVL is entering into this agreement solely on its own behalf and not on behalf of any other person or entity. In particular, it is expressly understood and agreed that the Govt. of India is not a party to this agreement and has no liabilities, obligations or rights hereunder. It is expressly understood and agreed that OVL is an independent legal entity with power and authority to enter into CONTRACT and is solely in its behalf under the applicable laws of India and general principles of CONTRACT Law. The CONTRACTOR expressly agrees, acknowledges and understands that OVL is not an agent, representative or delegate of the Govt. of India. It is further understood and agreed that the Govt. of India is not and shall not be liable for any acts, omissions, and commission, breaches or other wrongs arising out of the CONTRACT. Accordingly, CONTRACTOR hereby expressly waives, releases and forgoes any and all actions or claims, including cross claims, impleader claims or counter claims against the Govt. of India arising out of this CONTRACT and covenants not to the Govt. of India as to any manner, claim, cause of action or thing whatsoever arising of under this CONTRACT

**21. FORCE MAJEURE:**

In the event of either party being rendered unable by Force Majeure to perform any obligation required to be performed by them under the CONTRACT, the relative obligation of the party affected by such Force Majeure shall be suspended for the period during which such cause lasts. The term "Force Majeure" as employed herein shall mean acts of God, War, Civil Riots, Fire directly affecting the performance of the CONTRACT, Flood and Acts and Regulations of respective government of the two parties, namely OVL and the CONTRACTOR.

Upon the occurrence of such cause and upon its termination, the party alleging that it has been rendered unable as aforesaid thereby, shall notify the other party in writing, the beginning of the cause amounting to Force Majeure as also the ending of the said clause by giving notice to the other party within 72 hours of the ending of the cause respectively. If deliveries are suspended by Force Majeure conditions lasting for more than 2 (two) months, OVL shall have the option of canceling this CONTRACT in whole or part at his discretion without any liability at

his part. Time for performance of the relative obligation suspended by Force Majeure shall then stand extended by the period for which such cause lasts.

**22. EMPLOYMENT BY FIRMS TO OFFICIALS OF OVL**

Firms/companies who have or had business relations with OVL are advised not to employ serving OVL employees without prior permission in writing. It is also advised not to employ ex-personnel of OVL within the initial two years period after their retirement/resignation/severance from the service without specific permission of OVL in writing. The OVL may decide not to deal with such firms who fail to comply with the above advice.

**23. PREFERENCE TO LOCAL COMPANIES:-**

CONTRACTOR agrees to give priority and preference to locally owned companies, when hiring Sub CONTRACTOR, SUBJECT TO price, quality and delivery being equivalent.

**24. JURISDICTION AND APPLICABLE LAW:-**

This Agreement including all matter connected with this Agreement, shall be governed by the laws of India (both substantive and procedural) for the time being in force and shall be subject to exclusive jurisdiction of the Indian Courts (the place where the CONTRACT is signed in India). Foreign companies, operating in India or entering into Joint ventures in India, shall have to obey the law of the Land and there shall be no compromise or excuse for the ignorance of the Indian legal system in any way.

**25. ARBITRATION:**

Except as otherwise provided elsewhere in the CONTRACT if any dispute, difference, question or disagreement arises between the parties hereto or the respective representatives or assignees, at any time in connection with construction, meaning, operation, effect, interpretation or out of the CONTRACT or breach thereof the same shall be referred to Arbitration of Sole Arbitrator appointed by the Director of OVL.

It is also agreed that there will be no objection for appointment of an employee of OVL as Sole Arbitrator who also holds shares of OVL. Appointment of Arbitrator shall be made within 30 days of the receipt of the arbitration notice. If the Arbitrator so appointed dies, resigns, incapacitated or withdraws for any reason from the proceedings, it shall be lawful for the Director of OVL to appoint another person in his place in the same manner as aforesaid. Such person shall proceed with the reference from the stage where his predecessor had left if both parties consent for the same; otherwise, he shall precede de novo.

It is a term of the CONTRACT that the party invoking arbitration shall specify all disputes to be referred to arbitration at the time of invocation of arbitration and not thereafter. It is also a term of the CONTRACT that neither party to the CONTRACT shall be entitled for any ante-lite (pre-reference) or pendente-lite interest on the amount of the award.

The Arbitrator shall give reasoned award and the same shall be final, conclusive and binding on the parties. The venue of the arbitration shall be the place from where the purchase order / CONTRACT has been placed / made. It is a term of the CONTRACT that the cost of the arbitration will be borne by the parties in equal shares.

Subject to as aforesaid, the provisions of Arbitration and Conciliation Act 1996 and any statutory modifications or re-enactment in lieu thereof shall apply to the arbitration proceedings under this clause.

**26. CONTINUANCE OF THE CONTRACT: -**

Notwithstanding the fact that settlement of dispute(s) (if any) under arbitration may be pending, the parties hereto shall continue to be governed by and perform the work in

accordance with the provisions under this CONTRACT.

**27. INTERPRETATION: -**

The titles and headings of the sections in this CONTRACT are inserted for convenient reference only and shall not be construed and limiting or extending the meaning of any provisions of this CONTRACT.

**28. ENTIRE AGREEMENT: -**

This Agreement supersedes all prior Agreements and commitments, whether oral or in writing between the parties concerning the subject matters thereof. The right of either party to require strict performances will not be affected by any previous waiver or course of dealing. Neither this Agreement nor any modification will be binding on a party unless signed by an authorized representative of CONTRACTOR and OVL.

\_\_\_\_\_  
(Signature of tender issuing Authority)

\_\_\_\_\_  
(Signature of contractor with seal)

**BID EVALUATION CRITERIA**

A. Vital criteria for acceptance of bids:-

Bidders are advised not to take any exception/deviations to the bid document. ONGC-Videsh Ltd. after processing such suggestions may, through an addendum to the bid document, communicate to the bidders the changes in its bid document, if any. Still, if exceptions /deviations are maintained in the bid, such conditional/ non-conforming bids shall not be considered and shall be out rightly rejected.

B. REJECTION CRITERIA

B.1 Technical rejection criteria

The following vital technical conditions should be strictly complied with failing which the bid will be rejected:

1.0 Bid should be complete covering the Scope of work. Incomplete and non-conforming bids will be rejected outright.

2.0. Experience Criteria: The tender in sealed cover should contain the following:

- a. Earnest Money Deposit of requisite value in the form of crossed Demand Draft drawn on any Nationalized/ Scheduled Bank, payable at New Delhi or Pay Order from local bank
- b. Copy of valid electrical contractors' license/certificate of electrical contractor issued by state licensing board in the name of the bidder.
- c. Valid electrical supervisors' license issued by state licensing board in the name of the person(s) proposed to be employed for the work.
- d. As a proof of in line experience copy of work order(s)/work completion certificate(s) for the work of similar to that of as mentioned in the scope of work during last two years till 31.3.2008 should be either of following.

- i) Three works each costing not less than the amount equal to 40% of the estimated cost.

OR

- ii) Two works each costing not less than the amount equal to 50% of the estimated cost.

OR

- iii) One work costing not less than the amount equal to 80% of the estimated cost.

- e. Duly filled in & Signed Integrity pact on a stamp paper of Rs100/-

B.2 Commercial rejection criteria

1.0 The following vital commercial conditions should be strictly complied with failing which the bid will be rejected:

1.1 Bid should be submitted in Single Bid system. The bid shall contain all details including with the price column of the price bid format.

2.0 Acceptance of terms & conditions:

The bidder must confirm unconditional acceptance of all tender conditions.

3.0 Offers of following kinds will be rejected:

(a) Telex/ Telegraphic /Fax/ E-Mail/ Xerox/ Photo copy offers.

- (b) Offers which do not confirm unconditional validity of the bid for 180 days from the date of opening of bid.
- (c) Offers where prices are not firm during the entire duration of the contract and/or with any qualifications.
- (d) Offers which do not conform to ONGC-Videsh Ltd.'s price bid format.
- (e) Offers which do not confirm to the mobilization period indicated in the bid.
- (f) Offers which do not confirm to the contract period indicated in the bid.

4.0 Bidder shall bear, within the quoted rates, the Personnel Tax as applicable in respect of their personnel and their sub-contractor's personnel, arising out of this contract. Bidder shall also bear, within the quoted rates, the Corporate Tax, as applicable, on the income arising out of this contract.

#### C. Price Evaluation Criteria

The bids shall be compared and evaluated on the total lump sum amount. Accordingly, contract will be awarded.

Payments: 100% Payments will be made after satisfactory completion of the job.

#### D. General:

1. The BEC over-rides all other similar clauses operating anywhere in the Bid Documents.
2. The bidder/contractor is prohibited to offer any service / benefit of any manner to any employee of ONGC-Videsh Ltd. and that the contractor may suffer summary termination of contract / disqualification in case of violation.
3. On site inspection will be carried out by ONGC-Videsh Ltd's officers / representative /Third Parties at the discretion of the ONGC- Videsh Ltd.
4. Any other points arise during the tender/contract will be decided by ONGC-VL.
5. ONGC-VL reserves the right to reject any or all bidders at any time without assigning any reasons.

\_\_\_\_\_  
(Signature of tender issuing Authority)

\_\_\_\_\_  
(Signature of contractor with seal)

- **SPECIAL CONDITIONS OF CONTRACT**
- **SPECIAL INSTRUCTIONS**
- **PRICE PROFORMA**
- **SCOPE OF WORK**
- **LIST OF APPROVED MANUFACTURERS**
- **SINGLE LINE DIAGRAM**

**SPECIAL CONDITIONS OF CONTRACT**

- 1) The specifications for various items of the tender shall be the same as per relevant ISI specifications or the specifications as stipulated in this tender. Various items given in the tender are self explanatory, however for any ambiguity; reference will be made to the relevant specifications of the items as stated in the scope of work.
- 2) Under this contract, the contractor will have to execute all the work as ordered by work order from time to time by Engineer-In-Charge (EIC) of OVL within stipulated time. The rates to be paid to the contractor shall be those mentioned in the schedule of rates plus % above or below quoted by him attached to this agreement.
- 3) Engineer-in-charge shall be empowered to deduct the L.D. @ ½ % per week or part thereof up to maximum of 10% of the job value, if the job / work is not completed within stipulated time given by the EIC of OVL. The decision of EIC of OVL shall be final in this regard.
- 4) The contractor will submit bill in triplicate for work executed by him. The payment shall be made against such bill raised by the contractor, if found in order.
- 5) In case of any material supplied and/or work done is rejected owing to its not conforming to the specifications, such material/work should be removed from the site within 2 days of such rejection at contractor's cost, failing which the OVL will have the right to remove the same departmentally or through other agency at the risk and cost of the contractor without any notice.
- 6) OVL reserves the right to order any item/items of the tender independently as may be considered expedient. Contractor shall be bound to execute any item of the tender at his quoted rates if and when he is called upon to do so at any stage during the period of the contract.
- 7) The work involves working in all locations and under all conditions and for all surfaces, plain, curved etc. No perks on any account for reconsideration of rates will be entertained on any account whatsoever during the period of contract. No escalation or increase in rates shall be granted to the contractor during the entire period of contract including its extension thereof on any ground whatsoever.
- 8) The work shall be started at site only after written clearance is given by the OVL and shall be completed within the period stipulated by the EIC.
- 9) The rate quoted is deemed to cover working under adverse condition as well as supervision from the contractor's side.
- 10) The contractor will have to work in close cooperation and coordination with other agencies on the site as well as with the various department of the OVL. No extra claim on this account shall be payable by the OVL.
- 11) The OVL reserves the right to terminate this contract at any time during the currency of the contract, without assigning any reason thereof. Such termination will be communicated to the contractor in writing and any work affected beyond the date of termination of the contract shall not be measured and paid for.
- 12) The contractor shall arrange to obtain necessary entry permits for the labour as well as trucks and other equipments from security section / Building management Company that may be necessary to be taken inside the complex.

- 13) For the performance of this work the term Engineer-in-charge will mean the C.E. (E&T), OVL, New Delhi. The day to day instruction for the work and any clarification regarding specification for the various items shall be given by the EIC / Respective Area In-Charge or his authorized representative at site. These instructions and clarifications shall be final and binding on the contractor.
- 14) The contractor may have to work during night as well as during holidays and non-working days according to the exigencies of work. No extra claim on this account shall be entertained by the OVL.
- 15) Any breach of the conditions of the contract shall entail immediate withdrawal of the work and will be carried out through other agencies at the risk and cost of the contractor and all amounts which may be due to the contractor are liable to be forfeited.
- 16) The contractor shall execute his work in such a way as not to interfere with the functioning of the OVL, and also without any disturbance or damage to the existing structures and installation etc within the OVL's premises.
- 17) The contractor shall maintain registers for the complaints attended in all quarters, office buildings of the OVL as per the instructions of the EIC for scrutiny from time to time. The cost of the register shall be borne by the contractor and on completion of the job they shall be submitted to the OVL for records.
- 18) Any and all claims not specifically reflected and included in the final bill, in accordance with the provisions of Clause 4 of special conditions of the contract (Clause reg. Final bill) hereof shall be deemed to have been waived by the contractor and OVL shall have no liability in respect thereof and the Contractor shall not be entitled to raise or include in the final bill or subsequently at any time, any claim(s) other than those mentioned in the final bill.

---

(Sign. of Tender issuing Authority)

---

(Sign. Of Contractor with Seal)

## Special Instructions

1. The installation shall generally be carried out in conformity to the latest Indian Electricity Rules 1965, amended up to date and Indian Electricity Act 1910, the supplementary regulation of Electricity Department and Electricity Undertaking concerned and the practice recommended by IEE and ISI but where the specification or the special specification attached to the tender differ from those regulation, the specification in this tender shall be followed.
2. All materials, fittings etc. used shall conform to Indian Standard Specifications wherever these exist. In the case of materials for which Indian standard specifications do not exist, the materials shall be approved by the EIC.
3. If any of the material is found defective or below the normal standard, the EIC shall have the right to reject the same and the contractor shall have to replace the same to the satisfaction of the EIC , it would be replaced at the risk & cost of the contractor.
4. The work shall be carried out in an excellent workmanship manner without damaging the walls, ceilings, floors and roads and shall not mark the discrepancy of the place. Wherever walls, ceilings, floors or roads are broken or opened, these shall be finished to the original shape and coloured by the contractor at his cost and risk.
5. All road cuttings/RCC damage should be made good strictly as per original condition at his cost.
6. Tools, plants and labour required for the work shall not be provided by the OVL, and it shall be the sole responsibility of the contractor only.
7. The contractor shall ensure that the manpower utilized by him for the electrical works as laid down in the tender schedule should be competent and efficient enough to execute the work with full safety as per the rules and regulations of the OVL, and shall abide by the safety rules and regulations as laid down by the OVL from time to time.
9. **STATUTORY REQUIREMENTS:-**
  - a) During the tenure of this CONTRACT nothing shall be done by the CONTRACTOR in contravention of any law, act and / or rules / regulations, hereunder or any amendment thereof governing interalia customs stowaways, foreign exchange etc.
  - (b) Any statutory or otherwise increase in minimum wages and resultant increase in P.F., ESI, bonus & leave with wages etc. if applicable to the establishment of the contractor & the laborers engaged by him as well as to this contract from time to time , shall be paid by the contractor . OVL shall not be liable to pay any increase in payment of wages and resultant increase in P.F., ESI, bonus & leave with wages etc. to the contractor & his laborers on any ground whatsoever .
10. The contractor shall obtain license in the prescribed format under the contractor labour (Regulation& Abolition) Act1 1970 read with rules framed hereunder and furnished the same to OVL within 15 days of receipt of letter of intent but before the signing of formal agreement, failing which the letter of intent/contract shall be cancelled/terminated without any further notice in this regard and his bid bond and/ or performance bank guarantee shall be forfeited without prejudice to any other rights and remedies available to OVL under the contract. The contractor shall ensure that license remains valid during the entire period of contract including its extension there self.
11. **Sub-letting & Assignment**  
The contractor shall not, without the previous consent in writing of OVL, sub-let, transfer or assign the contract or any part thereof or interest therein or benefit or advantage thereof in any manner whatsoever. Provided nevertheless that any such consent shall not relieve the contractor from any obligation, duty or responsibility.
12. Taxes, Duties, etc.

All taxes including Income-tax, Sales-tax, Works contract tax, service tax, duties, fees etc. Shall be borne by the contractor and OVL shall not be liable to pay any taxes, duties, etc. on any ground whatsoever.

13. **SECURITY DEPOSIT:-**

- (i). The contractor shall be required to deposit security money (i.e. security deposit) for the amount equal to 10% of the total contract value with OVL in the form of demand draft drawn in favour of F& AO,ONGC Videsh Ltd, New Delhi payable at New Delhi or in the form of performance bank guarantee in the prescribed format of ONGC VIDESH LTD from a nationalized /schedule bank and shall remain valid for the period of contract including its extension, if any, thereof.
  - (ii). The Earnest money deposit (EMD) of the contractor will be adjusted towards security deposit and if so adjusted, the balance security money shall have to be deposited in the form indicated in the above clause.
  - (iii). The security deposit must be furnished by the contractor with in 15 days from the date of issue of LOI / work order, otherwise the LOI / work order shall be treated cancelled and EMD will be forfeited.
  - (iv). The security deposit is refundable without interest after successful completion of Contract period and warranty period, if any, subject to terms and conditions of this contract . OVL reserves its right to recover from security deposit any sum or dues outstanding against contractor including any amount on account of liquidated damages. Security deposit is also liable to be forfeited or appropriated towards the damages or losses that may sustained by OVL due to any omission or default by the contractor. Security Deposit may also be forfeited by OVL for any breach of contract by the contractor in the performance of his obligation under the contract.
14. The contractor shall be liable to pay the taxes whatsoever are imposed by the Government of Delhi / Govt. of India on all the items that are required to execute the jobs as per the tender schedule and directed by the EIC.
15. If any injury or death caused to the workmen to be engaged by the contractor or any other person or any damage is caused to the property of OVL or to other persons property, the Contractor shall be liable to pay the compensation to the contract labourers or other persons as the case may be and OVL shall not be liable to pay any compensation in this regard.
16. Termination for unsatisfactory performance: -  
If OVL considers that the performance of the CONTRACTOR is unsatisfactory or not up to the expected standard the OVL shall notify the CONTRACTOR in writing and specify in detail the cause of such dissatisfaction. The OVL shall have the option to terminate this agreement by giving 30 days notice in writing to the CONTRACTOR, if Contractor fails to comply with the requisitions contained in the said written notice issued by the OVL.
17. Termination for delay in mobilization: -  
Successful bidder shall be required to mobilize complete equipment along with crew (only crew in case of Operation and Maintenance Contracts) for commencement of services at the specified site within a maximum of 07 days from the date of Fax order/LOI NOA. The CONTRACT shall automatically stand terminated unless OVL has extended the mobilization period with levy of Liquidated Damages, as per Clause of the Special Conditions of Contract.

Consequences of termination: -

In all cases of termination herein set forth there will be NO obligation of OVL to pay. Notwithstanding the termination of this Agreement the parties shall continue to be bound by the provisions of this Agreement that reasonably require some action or forbearance after such termination.

17 In case of termination of CONTRACT herein set forth except under and, the contractor shall be put on holiday ( i.e. neither any enquiry will be issued to the party by OVL against any type of tender(s) where contract between OVL and that particular CONTRACTOR (as a bidder) has not been finalized for two years from the date of termination by OVL to such CONTRACTOR.

18. **WARRANTY:-**

The contract must warrant that every thing to be furnished hereunder shall be free from all defects and faults in material workmanship and manufacture and shall be of highest grade and consistent with established and generally accepted standards of the material of the type ordered, and in full conformity with the specifications, drawings, or samples, if any, and operable, operate properly. This warranty shall survive inspection of, the payment for and acceptance of the goods, but shall expire twelve months after their arrival at the destination

\_\_\_\_\_  
(Sign. of Tender issuing Authority)

\_\_\_\_\_  
(Sign. Of Contractor with Seal)

**PRICE FORMAT**

SI.No	Description	Amount (Rs.)
1.	Turnkey Job: Supply, installation and commissioning of modifications for existing electrical system/cabling and installation of MCCB and ATS/Source automatic changeover switch to Generator Backup facilities at 3 <sup>rd</sup> floor of Antriksh Bhavan as per the Tender Scope of work	

Total Rs. \_\_\_\_\_

Total in words Rupees \_\_\_\_\_

(SIGNATURE)

## Notes:

1. Bidder must quote their price strictly as per price format in Indian Rupees only.
2. Bidder should quote their price inclusive of all applicable taxes, VAT/CST/Excise duty including service taxes, if any. Bidder shall also bear the personnel tax and corporate taxes, if any, arising out of execution of this contract. ONGC-Videsh Ltd. does not take any liability in this account.

Signature of the Bidder with date  
Name of the firm with address

## Scope of Work

### General:

ONGC Videsh is planning for Connecting Generator Back-up facilities for the existing NDMC power distribution system at 3<sup>rd</sup> floor of Antriksh Bhavan. Generator back-up will be provided by Building Management of Antriksh Bhavan, M/s Star Estate Management Ltd. Scope of work includes carrying out the required modifications at Generator end in the basement of the building and at 3<sup>rd</sup> floor, Antriksh Bhavan for the existing electrical cabling and connecting automatic switchover facilities. After required modifications are carried out, changeover from NDMC to Generator automatic backup and restoration to normalcy will be tested for NDMC power failure and restore conditions.

### Detailed:

1. Supply, Installation, testing and commissioning of 600A, Microprocessor based ATS / Source Changeover Switch of Schneider/Legrand make including the factory fabricated enclosure complete as required, 35/36 KA breaking capacity at 3<sup>rd</sup> floor as per SLD.  
Quantity: 1 Nos.  
Preferred Makes: Legrand, Schneider, L&T, Merlin Gerin, Siemens
2. Supply, Installation, testing and commissioning of MCCB along with enclosure of 600 AMP., 4 P, MCCB of 35 KA breaking capacity in the Basement panel as well as at 3<sup>rd</sup> floor Antriksh Bhavan.  
Quantity: 2 nos  
Preferred Makes: Legrand, Schneider, L&T, Merlin Gerin, Siemens
3. Supplying, unloading, storing, laying, terminating with suitable terminators, testing and commissioning of following size of Aluminum /Copper conductor armored, Fire retardant cables suitable for working voltage up to and including 1100 Volts , laid and tied on existing overhead cable trays; or laid and tied over MS supports in masonry trenches including providing MS supports and clamps for fixing to supports in an approved manner complete as required and as per specifications from Generator end to 3<sup>rd</sup> floor Antriksh Bhanan (As per SLD).  
Length : 200 meters (approx).  
Size : 3.5 x 185 sq mm armoured and fire retardant cable.  
Preferred makes: Finolex, Unistar, Polycab, Torrent, Grandlay.
4. Supplying, unloading, storing , laying, terminating with suitable terminators testing and commissioning of following size of Copper conductor cables suitable for working voltage upto and including 415 Volts, for Link terminations (As per SLD).  
Length : 180 meters (approx).  
Size : 1 x 70 sq mm PVC insulated copper cable.  
Preferred makes: Finolex, Unistar, Polycab, Torrent, Grandlay.
5. To carry out required modifications in the Existing Power panel Distribution Board of 3<sup>rd</sup> floor Antriksh Bhavan and at Generator end of Building Management Company.

6. Supply and termination suitable aluminum and copper terminators, suitable to the cables sizes mentioned above.
7. Co-ordination with building authorities for carrying out the execution of the job is the sole responsibility of the contractor.
8. The material supplied under this work shall carry a warranty of 1 year and the bidder will be responsible for any defects which may arise during the warranty period
9. Installation and Commissioning of the entire change over facility is as per the electrical single line connectivity diagram attached along with Scope of work.
10. Panel of requisite dimensions for installation of ATS and MCCB is in the scope of the bidder

Notes:

1. Installation and commissioning jobs are required to be taken up preferably on closed holidays, to avoid disruption of providing services with specific approval of Engineer In charge.
2. The quantities given above are indicative numbers only and all the bidders are allowed to make site visit and assess their own before submission of their final quote.
3. The bidder should indicate make, model and specifications of the material which will be used for execution of the said job.

**LIST OF APPROVED MANUFACTURERS**

1. 600A, Microprocessor based ATS / Source Changeover Switch of Schenider/Legrand make including the factory fabricated enclosure complete as required, 35/36 KA breaking capacity.

Makes: Legrand, Schneider, L&T, Merlin Gerin, Siemens

2. MCCB along with enclosure of 600 AMP., 4 P, MCCB of 35 KA breaking capacity.

Makes: Legrand, Schneider, L&T, Merlin Gerin, Siemens

3. Aluminum /Copper conductor armored, Fire retardant cables suitable for working voltage up to and including 1100 Volts , Size: 3.5 x 185 sq mm

Makes: Finolex, Unistar, Polycab, Torrent, Grandlay.

4. Copper conductor cables suitable for working voltage upto and including 415 Volts, for Link terminations. Size: 1 x 90 sq mm PVC insulate copper cable.

Makes: Finolex, Unistar, Polycab, Torrent, Grandlay.

**Signature of CE (E&T)**

# SINGLE LINE DIAGRAM

Appendix vi

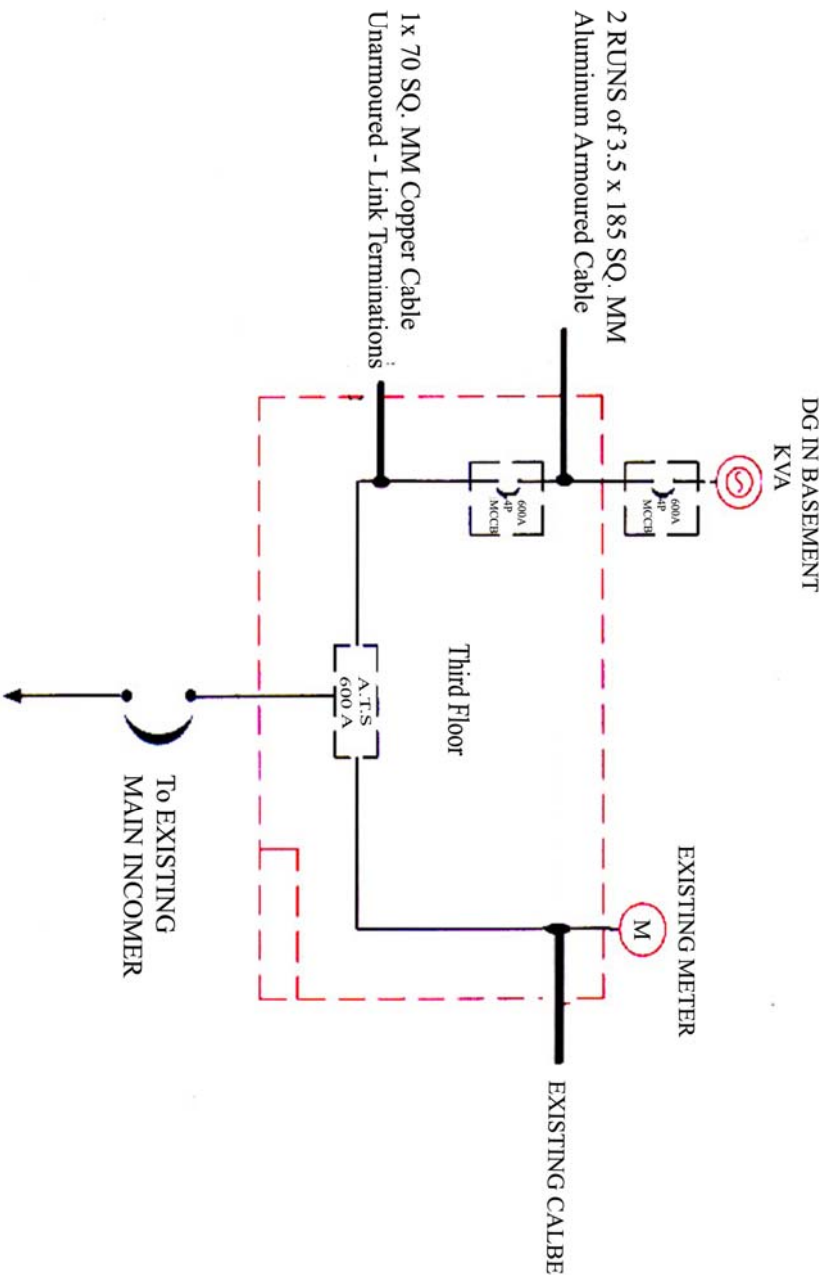

**Location: 3rd Floor Antriksh Bhawan  
22 K G Marg,  
New Delhi 110001**

**Proforma of Agreement**

THIS AGREEMENT made on Date \_\_\_\_\_ 2007 ( Two thousand seven) between ONGC VIDESH LTD, having its Registered office at 6<sup>th</sup> Floor, Kailash Building, 26, KG Marg, Connaught Circle, New Delhi (hereinafter called 'OVL' of the one part and M/s. \_\_\_\_\_ (hereinafter called 'The Contractor' of the other part).

Whereas OVL being desirous of getting executed the work "**DG Connectivity work at 3<sup>rd</sup> floor, Antriksh Bhavan, KG Marg, New Delhi as per the Scope of work**" and had invited tenders for the same. AND WHEREAS the Contractor's tender has been accepted by the competent authority on behalf of OVL for execution of said work at the quoted / agreed rates.

AND WHEREAS the Contractor has deposited a sum of Rs. \_\_\_\_\_ In the shape of Bank Draft/ Banker Cheque No. \_\_\_\_\_ dated \_\_\_\_\_ drawn on \_\_\_\_\_ as earnest money pledged to the F&A.O, ONGC Videsh Ltd, New Delhi for due and faithful performance of the contract and further agreed to execute the said work according to the Conditions of Contract, Specifications, Scope of work, Maintenance Schedule, Schedule of work items of works, bill of quantities and tendered rates (hereinafter referred to as "The Documents")

Now it is hereby agreed as follows:-

THAT pursuance of this agreement and in consideration of the payment to be made by the OVL to the Contractor, the contractor shall duly perform the said work and shall execute the same with great promptness, care and accuracy in workman like manner and with best materials to the satisfaction of the corporation in accordance and in all respect with the said documents.

In witness whereof the parties here have signed this agreement on the Day and year first above written.

Signed & sealed for and  
on behalf of the said

Signed & sealed for and  
on behalf of the said OVL

-----  
(Signature with seal)

**Witness:-**

1. Signature \_\_\_\_\_  
2. Name \_\_\_\_\_  
Address \_\_\_\_\_

-----  
(Signature with seal)

2. Signature \_\_\_\_\_  
Name \_\_\_\_\_  
Address \_\_\_\_\_

**Note:-**

The agreement shall be executed on non-judicial stamp paper of Rs.100/- Paper can be in the name of either party.